

## Technical data



# Ameise PTE 1.3 Li-Ion

Electric pedestrian pallet truck (1,300 kg)

# Ameise PTE 1.3 Li-Ion

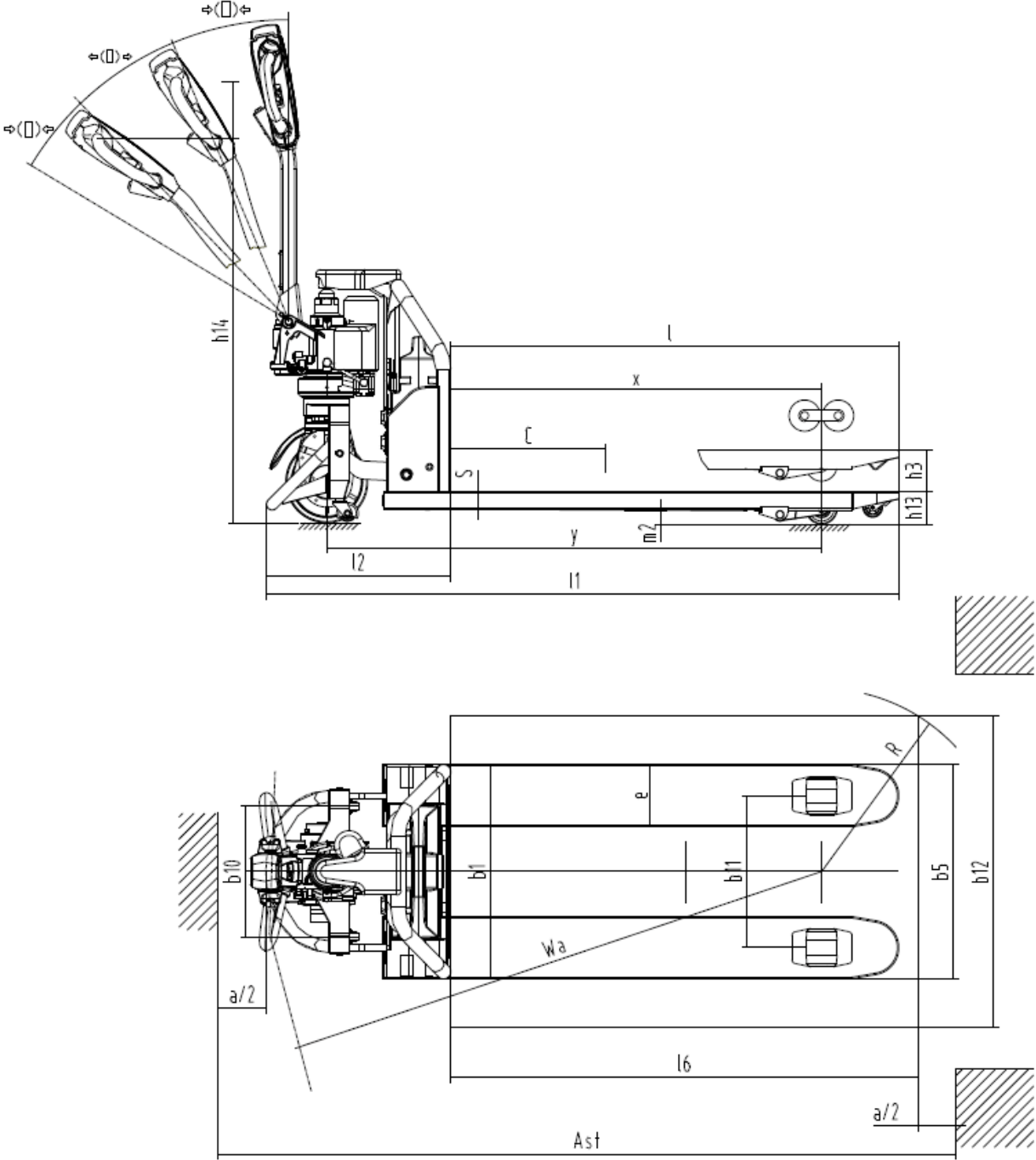

# Technical data as per VDI 2198

Stand-on: 06/2020

Kennzeichen	1.2	Manufacturer's type designation		Ameise PTE 1.3 Li-Ion				
	1.3	Drive		electric				
	1.4	Operation		Pedestrian				
	1.5	Load capacity/load	Q	kg	1.300			
	1.6	Load centre distance	c	mm	600			
	1.8	Load distance, centre of drive axle to fork	x	mm	601	951	601	951
Gewichte	2.1.1	Service weight (incl. battery)		kg	135			
	2.2	Axle load laden front/rear		kg	511 / 924			
Räder/Fahrwerk	3.1	Tyres		PU				
	3.2	Tyre size, front		Ø 210 x 70				
	3.3	Tyre size, rear		Ø 80 x 70				
	3.4	Additional wheels		Ø 42 x 17				
	3.5	Wheels, number front/back (x=driven)		1x +2/4				
	3.6	Tread width, front	b <sub>10</sub>	mm	335			
	3.7	Tread width, rear	b <sub>11</sub>	mm	390		525	
Grundabmessungen	4.4	Lift (h3)	h <sub>3</sub>	mm	110			
	4.9	Height of tiller handle in drive position min./max.		mm	635 / 1.200			
	4.15	Height, lowered	h <sub>13</sub>	mm	80			
	4.19	Overall length	l <sub>1</sub>	mm	1.273	1.623	1.273	1.623
	4.20	Length including fork shank	l <sub>2</sub>	mm	473			
	4.21.2	Overall width	b <sub>2</sub>	mm	550		685	
	4.22	Fork dimensions	s/e/l	mm	45 / 160 / 800	45 / 160 / 1.150	45 / 160 / 800	45 / 160 / 1.150
	4.25	Width across forks (dimension 1), WaF	b <sub>5</sub>	mm	550		685	
	4.32	Ground clearance centre of wheelbase	m <sub>2</sub>	mm	35			
	4.34	Aisle width (pallet 1000x1200 sideways)	Ast	mm	1.996	2.226	1.996	2.226
	4.34.1	Aisle width (pallet 800x1200 length)	Ast	mm	1.995	2.095	1.995	2.095
4.35	Turning radius	W <sub>a</sub>	mm	1.076	1.424	1.076	1.424	
Leistungsdaten	5.1	Travel speed laden/unladen		km/h	4,8 / 5			
	5.2	Lift speed laden/unladen		m/s	0.03 / 0.03			
	5.8	Max. gradeability laden/unladen		%	5 / 20			
	5.10	Service brake			electromagnetic			
E-Motor/ Elektronik	6.1	Drive motor, performance S2 60 min		kW	0.65			
	6.2	Lift motor, performance with S3		kW	0.8			
	6.4	Battery voltage/nominal capacity		V / Ah	48 / 20			
	6.5	Battery weight		kg	8.5			
Sonstiges	8.1	Type of drive control			Impulse/DC			
	10.7	Sound level as per EN12053, operator's ear		dB (A)	70			

- This data sheet according to VDI guideline 2198 only states the technical values of the standard truck. Different tyres, other masts, additional equipment etc. may result in different values.